

Rear Expansion Bay

You can select from the following options.

FZ-VSCG211	FZ-VRFG211	FZ-VFPG221	FZ-VFPG222
Smart Card Reader	HF RFID Reader	Fingerprint Reader (Windows Hello)	Fingerprint Reader (Windows Hello, Multi User authentication)

IMPORTANT

- <Only for model with Fingerprint Reader (Windows Hello, Multi User authentication)>

Before using the fingerprint reader (Windows Hello, Multi User authentication), you need to change following settings.

1. Click  (Start) - [Settings] - [System] - [Recovery].
2. Click [Restart now] in “Advanced startup”.
3. Click [Restart now] on the “We’ll restart your device so save your work” screen.
4. Click [Troubleshoot] - [Advanced options] - [UEFI Firmware Settings] - [Restart].
The computer restarts, and the Setup Utility screen appears.
5. Select the [Exit] menu, and then double-click [Load Default Values].
If the “Load Optimized Defaults” is displayed, click [Yes].
6. Select the [Security] menu, and then confirm [Enhanced sign-in security] is set to [Disabled].
7. Select the [Exit] menu, and then double-click [Save Values and Reboot].
If the “Save Values and Reboot” is displayed, click [Yes].

Inserting an option to the rear expansion bay

1. Turn off the computer and disconnect the AC adaptor.

IMPORTANT

- We recommend that you turn off the computer completely the following.

1. Click  (Start) - [Settings] - [System] - [Recovery].
2. Click [Restart now] in “Advanced startup”.
3. Click [Restart now] on the “We’ll restart your device so save your work” screen.
4. Click [Turn off your PC].

2. <For tablet> Turn your tablet over.

Make sure no foreign objects are under the tablet.

3. Remove the battery pack. ( [Replacing the Battery Pack](#))

4. Insert an option to the rear expansion bay.

- The dummy cover may have been inserted.

1. <Only for standard model> Remove the screw (A).

Use the PH 0 (PH #0) screwdriver.

For the appearance of the standard model, refer to “[Description of Parts](#)”.

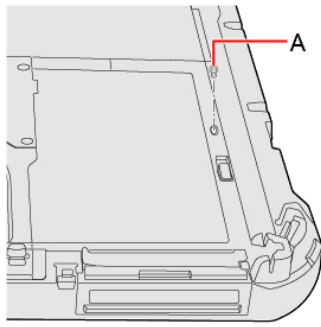

2. While sliding the rear expansion bay latch (B), remove an option.

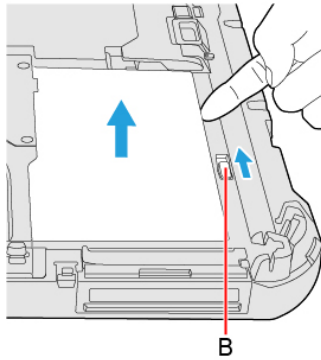

3. Insert the projection part (C) of the option into (D) part, and attach it while lowering until it clicks into place.

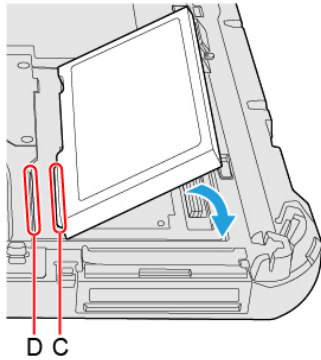

4. <Only for standard model> Tighten the screw (E) firmly.
For the appearance of the standard model, refer to "[Description of Parts](#)".
Use the PH 0 (PH #0) screwdriver.
Use 1 screw.

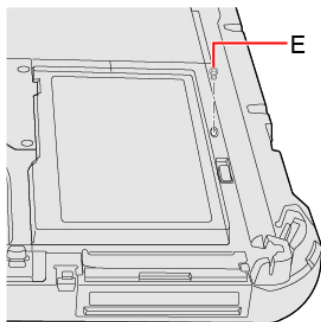

Recommended tightening torque
0.2 N•m ± 0.02 N•m (2.0 kgf•cm ± 0.2 kgf•cm)

5. Insert the battery pack.